

Hypertherm®

powermax1000® G3 SERIES™

Hand torch parts

T60 consumables



Powermax1000



T60 Torch

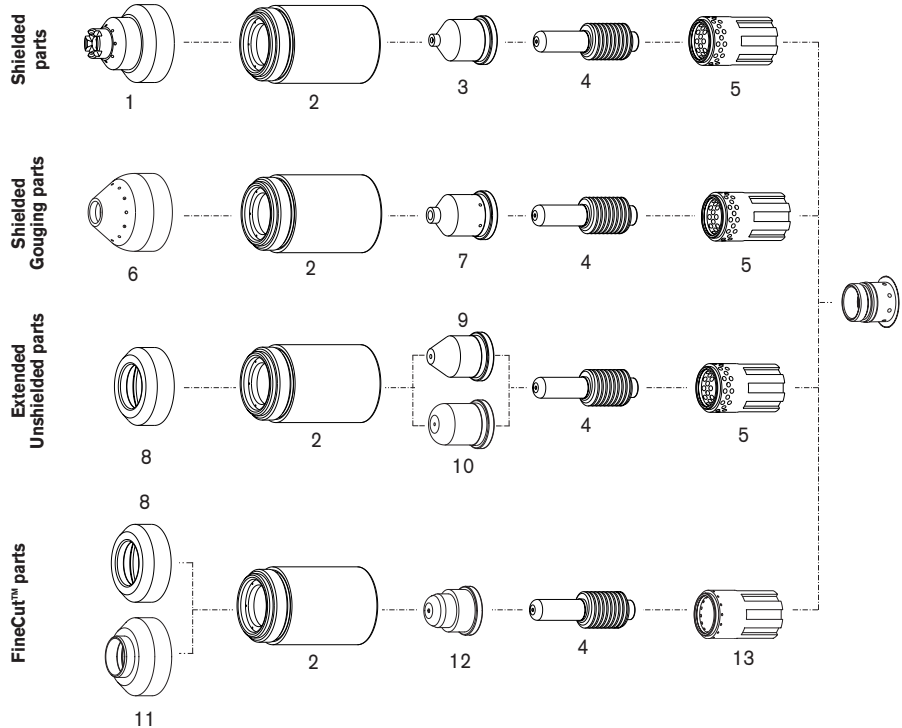

	ITEM NUMBER	PART NUMBER	DESCRIPTION	QUANTITY PER PACKAGE
Shielded parts	1	120929	Shield	1
	2	120928	Retaining Cap	1
	3	120931	Nozzle, 60 Amp	5
	3	120932	Nozzle, 40 Amp	5
	4	120926	Electrode	5
	5	120925	Swirl Ring	1
Shielded Gouging parts	6	120977	Shield, Gouging	1
	2	120928	Retaining Cap	1
	7	220059	Nozzle, Gouging	5
	4	120926	Electrode	5
	5	120925	Swirl Ring	1
Extended Unshielded parts	8	120979	Deflector	1
	2	120928	Retaining Cap	1
	9	220007	Nozzle, Extended, 60 Amp	5
	10	220006	Nozzle, Extended, 40 Amp	5
	4	120926	Electrode	5
	5	120925	Swirl Ring	1
FineCut™ parts	8	120979	Deflector	1
	11	220325	Deflector, CE	1
	2	120928	Retaining Cap	1
	12	220329	Nozzle, T60/T80/T100	5
	4	120926	Electrode	5
	13	220327	Swirl Ring	1

Genuine Hypertherm Consumables

The only way to ensure maximum performance

WARNING

* In countries following CE standards, unshielded consumables may only be used in mechanized torch applications.

Powermax1000 T60 trigger torch assembly

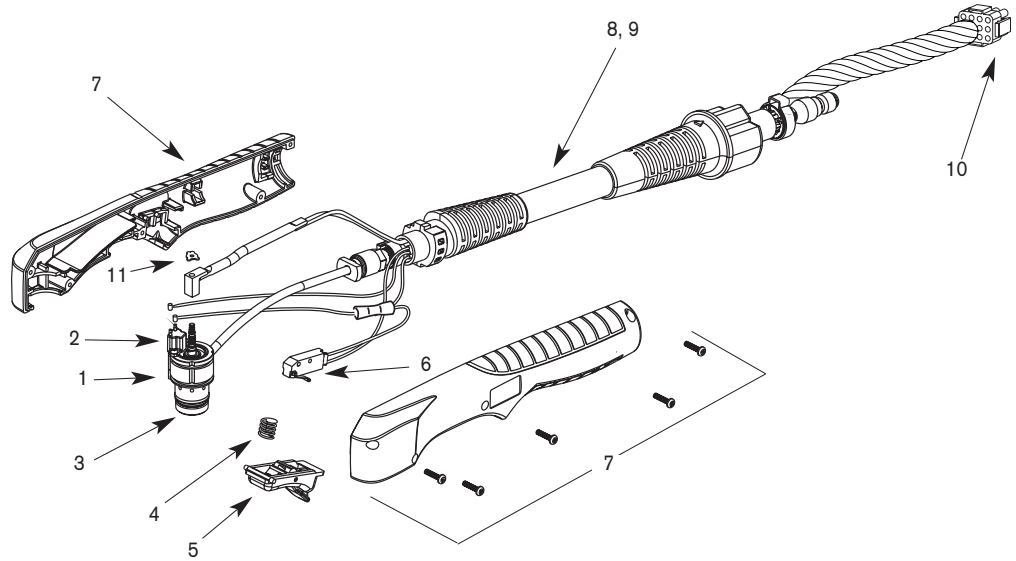

T60 Torch

ITEM NUMBER	PART NUMBER	DESCRIPTION
	083172 [^]	T60 Hand Torch Assembly, 25' (7.6 m)
	083171 [^]	T60 Hand Torch Assembly, 50' (15.2 m)
1	128564	Kit: T60/T80 Torch Main Body Replacement
2	128639	Kit: Cap Sensor Switch Replacement
3	128521	Kit: T60/T80, T60M/T80M Torch Head Repair
4	027254	Trigger Spring
5	002244	Safety Trigger Assembly
6	128642	Kit: T60/80 Start Switch Replacement
7	128644	Kit: T60 Torch Handle Replacement
8	128681	Kit: T60 Lead Replacement 25' (7.6 m)
9	128682	Kit: T60 Lead Replacement 50' (15.2 m)
10	128638	Kit: ETR Connector Repair (Regional Repair Centers Only)
11	027889	Retaining Clip

[^] Assembly includes consumables

Hypertherm, Powermax, G3 Series, FineCut and PAC are trademarks of Hypertherm, Inc. and may be registered in the United States and/or other countries.

Hypertherm®

The world leader in
plasma cutting technology™

www.hypertherm.com

Hypertherm, Inc. USA 603-643-3441 Tel 603-643-5352 Fax consumable.info@hypertherm.com

Hypertherm Automation, LLC USA 603-298-7970 Tel 603-298-7977 Fax info@hyperthermautomation.com

Hypertherm Plasmatechnik, GmbH Deutschland 49 6181 58 2100 Tel 49 6181 58 2134 Fax
HTDeutschland.info@hypertherm.com

Hypertherm (S) Pte Ltd. Singapore 65 6 841 2489 Tel 65 6 841 2490 Fax
HTSingapore.info@hypertherm.com

Hypertherm (Shanghai) Consulting Co., Ltd China 86-21-5835-5362 /3 Tel 86-21-5835 5220 Fax
HTChina.info@hypertherm.com

Hypertherm UK, Ltd. England 44 1928 579 074 Tel 44 1928 579 604 Fax HTUK.info@hypertherm.com

France 00 800 3324 9737 Tél 00 800 4973 7329 Fax HTFrance.info@hypertherm.com

Hypertherm S.r.l. Italia 39 02 725 46 312 Tel 39 02 725 46 400 Fax HTItalia.info@hypertherm.com

Hypertherm Europe B.V. Nederland 31 165 59 69 07 Tel 31 165 59 69 01 Fax
HTEurope.info@hypertherm.com

Japan 81 05 5975 7387 Tel 81 05 5975 7376 Fax HTJapan.info@hypertherm.com

Hypertherm Brasil Ltda. 55 21 2278 6162 Tel 55 21 2578 0947 Fax HTBrasil.info@hypertherm.com